

ERGO_{DC}

Dual Motor Height Adjustable Installation Manual

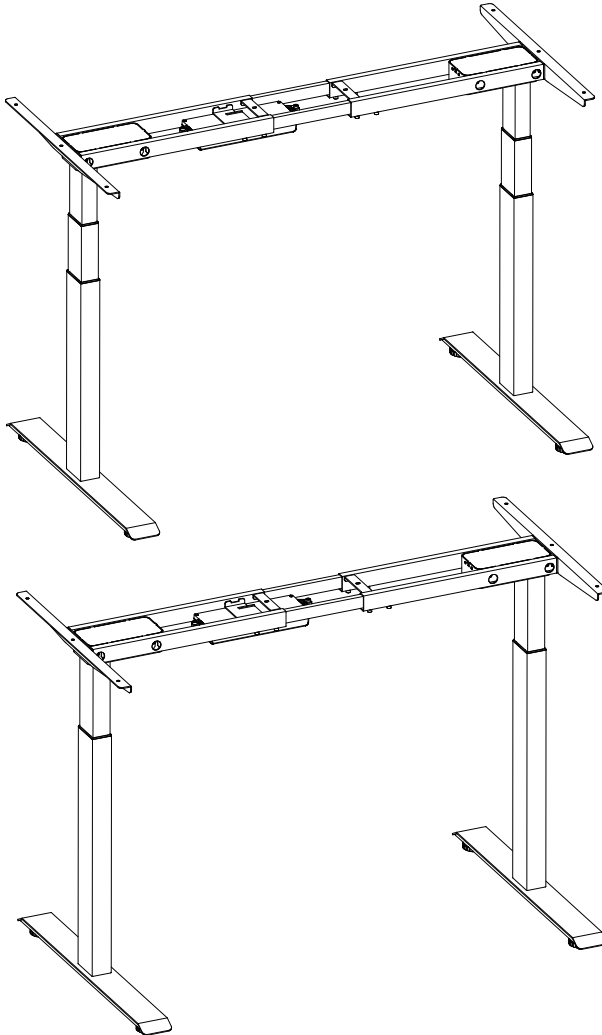

TABLE OF CONTENTS











▶ Safety Instructions	-----	1
▶ Components List	-----	2
▶ Installation Steps	-----	3
▶ Controller Manual	-----	6

SAFETY INSTRUCTIONS

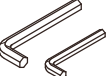
Read the operating instructions completely.

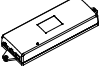
1. Failure to comply with instructions may result in serious damage to the system or one of its components.
2. Person who do not have the knowledge of the product(s) or have reduced physical or mental abilities must not use the product(s) unless they are under surveillance or they have been thoroughly instructed in the use of the apparatus by a person who is responsible for the safety of these persons.
3. It is important for everyone who is to connect or use the systems to have the necessary information and access to this User Manual.
4. The appliance is not intended for use by young children or infirm persons without supervision. Young children should be supervised to ensure that they do not play with the appliance.
5. Before troubleshooting
 - Stop the desk legs
 - Switch off the power supply and pull out the mains plug.
 - Remove everything from the desk top which might contribute weight.
6. Before start-up:
 - Make sure that the power supply is 220v before plugging the keyboard in to it.
 - The individual parts must be connected before the control box is connected to the main power supply.
7. During operation:
 - If the control box makes unusual noises or smells, switch off the main power immediately.
 - Take care that the cables are not damaged.
 - Unplug the main power cable on mobile equipment before it is moved.
8. Product continuous working time not more than 2 minutes, need to stop for 18 minutes after continuous work.
9. This product requires two people to carry.
10. **Warning!** Do not apply to oil, water and corrosive liquid to the Desk.

COMPONENTS LIST

<p>A</p>  <p>M6*16(16)</p>	<p>B</p>  <p>M6*20(9)</p>	<p>C</p>  <p>ST3.5*16(4)</p>	<p>D</p>  <p>Gasket (8)</p>	<p>E</p>  <p>4mm(1)/ 5mm(1)</p>	<p>F</p>  <p>Tie (3)</p>
<p>G</p>  <p>ST4.8*19 (3)</p>	 <p>Control Box (1)</p>	 <p>Flat Guide(4)</p>	 <p>Keypad (1)</p>	 <p>Power Cord (1)</p>	 <p>extended line(1)</p>

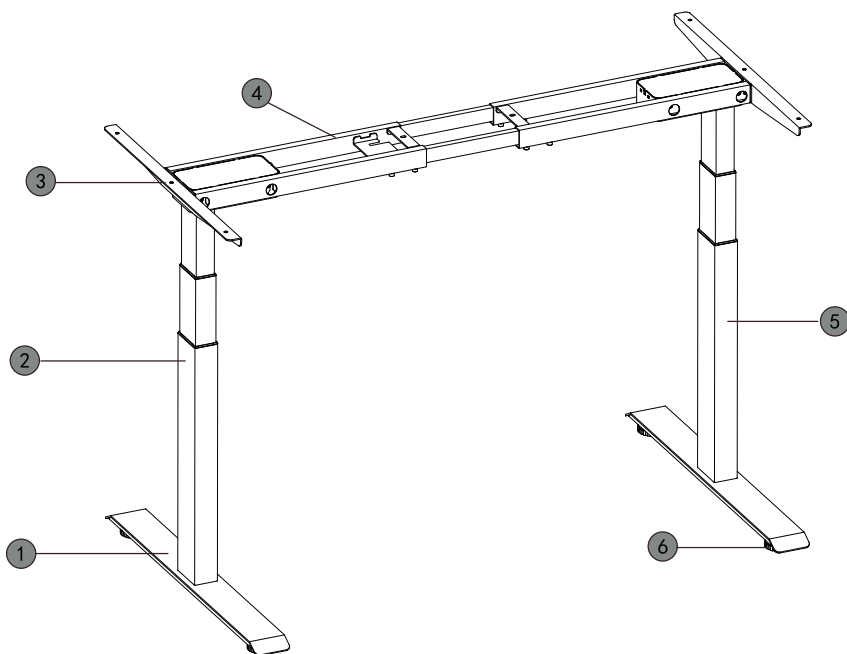

① Desk Feet

② Left Leg

③ Desktop Brackets

④ Crossbar

⑤ Right Leg

⑥ Flat Guide

INSTALLATION

- 1** Loosen the screw and adjust the length of the table to expose the mounting holes on the side of the cross bar.

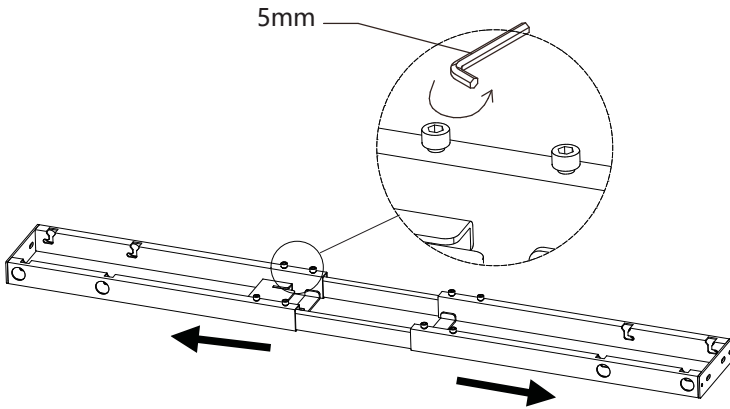

- 2** Install the leg on both left and right sides.

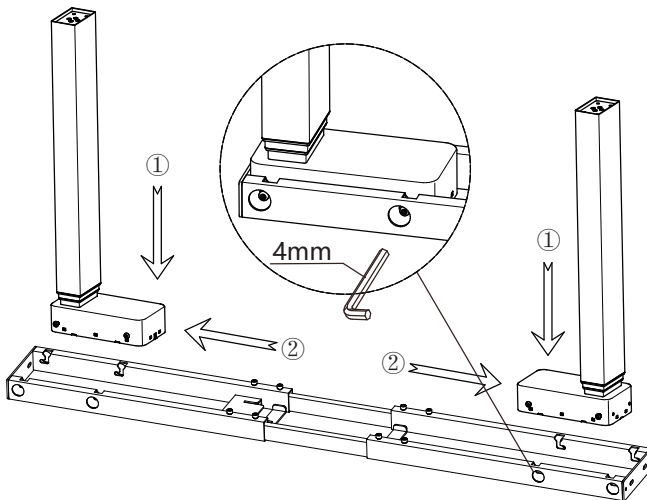

3 Install the desk feet and adjustable feet.

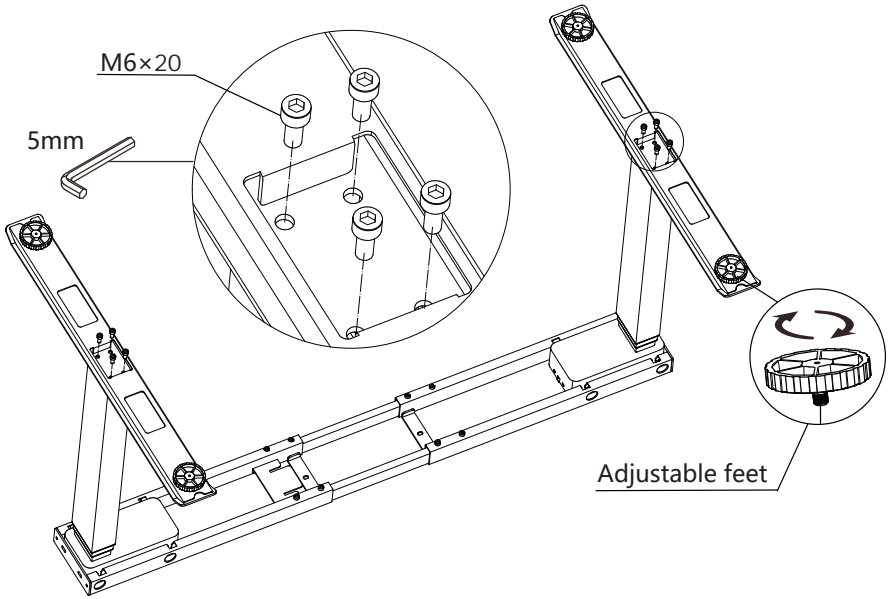

4 Install the desktop brackets and gasket.

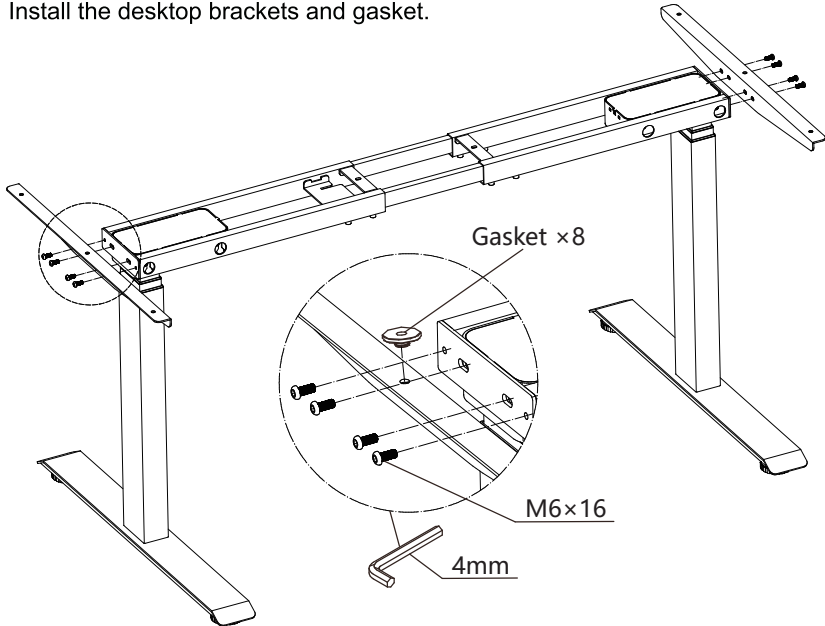

5

Install the table board
Install the manual controller

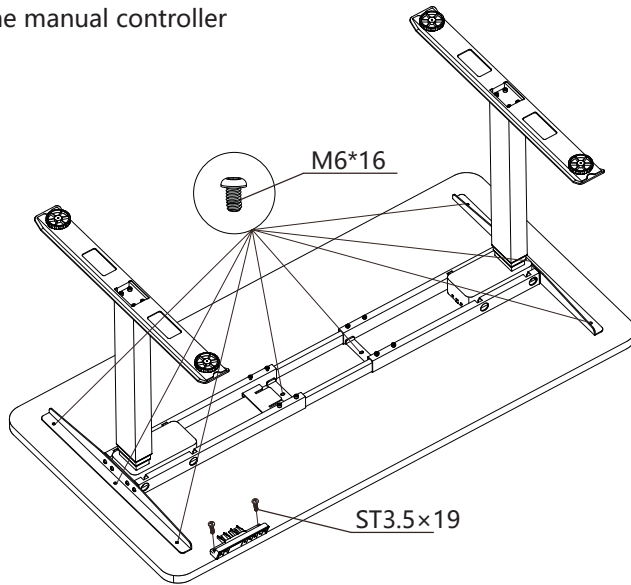

6

Install control box and wires.
The control box can also be fixed
under the desktop by ST4.8X19.S

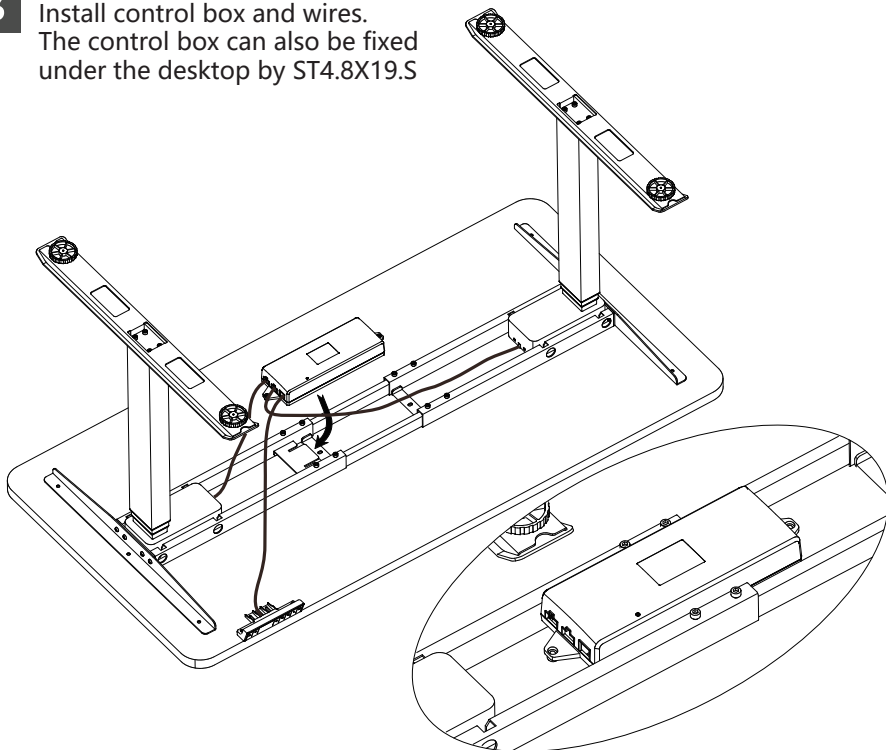

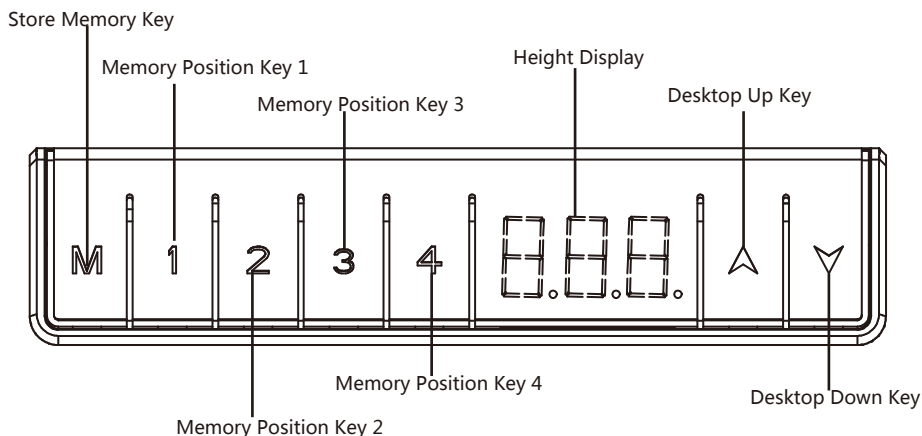

Controller Manual

1. Overview



2. Control Panel Function and Operation

	Function	Description	Note
 Desktop Up Key	Desk Upwards	For an upward adjustment of the desk push this button. Push this button until the desired height of the desk has been reached.	The desk will continue driving upwards until you release the button, or the maximum height is reached
 Desktop Down Key	Desk Downwards	For a downward adjustment of the desk push this button. Push this button until the desired height of the desk has been reached.	The desk will continue driving downwards until you release the button, or the minimum height is reached

3. Storing a Position

You can use this function to adjust the desktop to a saved height with 4 positions. If you are switching on the control unit for the first time, all the saved position are set to the lowest desktop height, to change to a saved position proceed as follows:



a. Press the UP or DOWN key to adjust the desktop to the desired height, the display will show the desktop height.



b. Press and hold the "M" Key for 3s until the Numbers on the display started flashing.



c. Press Memory Position Key 1 to save the desk position in memory.



d. The display will read "P 1" the memory position number you saved.



The other position may be stored in the same way.

4. Using Memory Positon

Press and release the 1, 2, 3 or 4 memory key, then press and hold the up or down arrow, the desk will move to the stored height, and show the height in the display.





5. The System Reset

You can reset the desk position if system with any arrows, to reset position proceed as follows:

Press and hold the key of "  "and "  " at the same time for 10 seconds until the desk reaches its lowest height, the display will be showed " RES ", and the system will make a sound of beep, reset is complete.

6. The Unit Switch

The height unit can be switch between CM and Inch, check the procedure below:

1. Press and hold the key of "  "and "  " at the same time for 3 seconds until the display readout "C-E", Press "  ", height unit will readout in "cm", and Press "  ", height unit will readout in "inch"

Note:

1. The system need to be waiting for 18 minutes after using 2 minutes, its motor heating protection. The display will showed "hot",
2. Make sure the desktop is not touching any liquid.
3. If any problem of items, please contact the seller, don't disassemble the product by yourself.

7. Setting The Led Retracted Height

Press the DOWN button on the memory controller until the frame reaches its lowest position. Measure the height of the frame from the floor and if the number on the LED display does not match your measurement, follow these steps:

- a. Press and hold the DOWN button (about 5 seconds) until the LED displays the flashing starting height.
- b. Press the UP or DOWN button to increase or decrease the height (1unit / click).
- c. Then press "M" and stop flashing, your desk is now ready to use.

Note: the LED display has a ± 0.1 tolerance.

8. Specifications

Tube Material	Steel
Expandable desk frame	41.3" - 63.0" / 105 - 160cm
Frame Adjustable Height	25.4"- 51.0" / 64.5 - 129.5cm
Depth of desk frame	22.6" / 57.4cm
Load Capacity	265 lb / 130kg
Speed	1.5" / s , 38mm / s

8. Trouble Shooting

Below are the possible errors which can be displayed. The errors will only be displayed when a button is pressed.

Error code	Description	Resolve
E01/E02	Lifting speed of two legs are not able to sync or HALL signal failure	Confirm that all wired connections are secure (legs to cables, cables to control box).
E03	The control box is tilted	Fix the control box to ensure that the control box is horizontal and the power cord is not tight during the item is working.
E04/E08	lifting column has overload, over-current protection	Remove everything from the desktop and perform the reset procedure outlined in the Digital Memory Controller section. (better to hold for 18 minutes)
E10	Leg 1 has collided and rebounded	The desk will automatically stop and bounce back 2 cm. Perform the reset procedure outlined in the Digital Memory Controller section
E20	Leg 2 has collided and rebounded	The desk will automatically stop and bounce back 2 cm. Perform the reset procedure outlined in the Digital Memory Controller section
HOT	Over heating protection	Wait for 18 minutes to restart

If the error message persists after the reset procedure, please contact us.